

Hako

**Superior technology
for industrial cleaning**

Ride-on vacuum sweeper Hako-Jonas 980

NEW!



**Extremely economical vacuum sweeping. Choice of high dump.
Up to 7.200 m² cleanliness/hour. For indoor and outdoor use.**

**Hako –
perfect from
product
to service.**

The compact ride-on v

The advantages at a glance:

Point 1

Perfect sweeping result thanks to the large, newly developed main broom with compensation for wear and tear. Powerful, efficient vacuum blower.

Point 3

Intelligent disposal concepts: hydraulic high dump up to 135 cm dump height or manual hopper emptying.

Point 5

For continual, professional use: robust construction with sturdy steel frame and practically indestructible synthetic material panels.

Point 2

Extremely manoeuvrable as a result of the directly steered front wheel drive.

A pleasure to operate, which still proves fun even in the most narrow aisles.

Point 4

Ergonomically optimised workplace for fatigue-free operation. Minimal training times as the result of self explanatory, operator-friendly handling and operation.

Point 6

Ingeniously simple: Service-friendly and robust. Avoids sources of malfunctions by concentrating on what's important.



Hako-Jonas 980 V: For outdoor applications with hydrostatic drive and rpm adjusted petrol engine. Cold start even in temperatures below zero.



Hako-Jonas 980 E: For exhaust-free indoor applications with electric drive and different types of battery system. Running time up to 4,5 hours.

vacuum sweepers Hako

Well thought-out construction:



Handy operating panel

All operational elements and warning indicators are within direct view and easy reach of the operator.

Central on/off switch combined with the main broom left is effected via a positioning lever which is easy to operate.

Operation of the bypass flap and the shaker from the operating panel.

Operator can mount the machine from both sides.

Adjustable driver's seat for fatigue-free operation.

Optimum view of the area to be cleaned.



Extremely manoeuvrable.

The steering angle of the Jonas 980 amounts to 90° in both directions and makes it possible to turn in aisles of 180 cm widths.



Simple, practical

Transport holder for brushes and cleaning utensils. Storage area for the operator's belongings.



Direct access. The engine compartment is clearly laid out and is directly accessible for maintenance and servicing purposes via the seat console which simply tilts backwards.



Robust main broom system

The large, newly developed main broom with wrap-around protection and patented broom holder can be changed without tools.

The side brush unit offers optimum adaptation to the contours of the application to be cleaned.

The large diameter and the strong bristles of the side brushes make sweeping of coarse dirt and debris from edges and outer areas much easier.

Powerful drive with automatic adjustment of the belt tension.



Side brush unit

The suspended side brush unit has collision protection to enable working close to edges.



Climbing ability

The powerful drives of the Hako Jonas 980 enables it to negotiate gradients of up to 16%.



Central sweeping level adjustment, without tools

This guarantees the right level and even pressure is exerted by the suspended main broom.

-Jonas 980 / 980 H.

Filter and disposal systems:

Efficient filter systems

The 3 m² plate filter package is integrated in the blower casing and is easily accessible.

Long intervals between cleaning can be achieved via an electric filter shaker system.

The degree of separation amounts to >99%.

The filter system is protected against wetness and wet debris by a bypass flap.

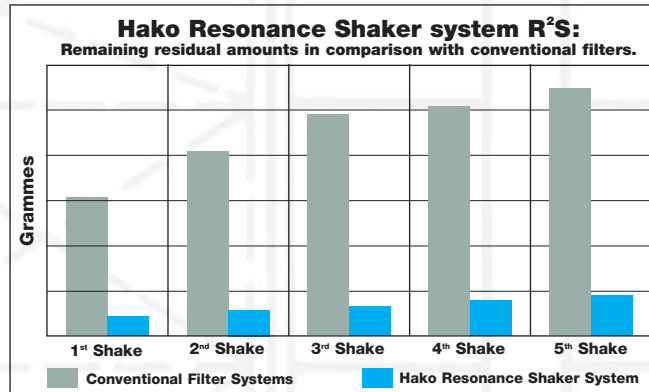

The dirt disposal concept „Take it easy”...

At any time checks can be made on the level of debris or bulky rubbish can be placed in the hoppers via the central lever on the hopper lift. ❶ The two 30 litre hoppers can be removed without getting your hands dirty ❷ and can be emptied easily by one person. ❸



...or the convenient dirt high dump

The handy high dump of the dirt hopper is operated directly from the driver's seat. A safety feature is the two handed operation for the hydraulic high dump of the 60l capacity dirt hopper, a function which is integrated in the operating panel. With a dump height of 135cm dirt and debris can be disposed off directly into standard rubbish containers.



The choice is yours!

Options:

We've thought of everything:

Overhead guard:

Increased safety for applications e.g. in warehouses with high level racking.



LPG Kit:

For low level exhaust emissions – operation with combustion engine in indoor applications.



Sprung driver's seat:

Additional comfort for continual usage or on uneven outdoor surfaces.



Battery-vacuum:

For the cleaning of inaccessible areas.



Working lights/ flashing beacon:

For improved vision and increased safety for indoor applications.



Lighting kit:

For use on public roads.



The technical data at a glance:

| Vacuum Sweeper | | Hako-Jonas 980 V | Hako-Jonas 980 E |
|------------------------------|----------------|---|--------------------------|
| Type of drive: | | Kawasaki petrol engine | Battery drive |
| Capacity: | kW | 6,0 | 2,0 |
| Sweeping width: | mm | 700 without side brush, 950 with 1 side brush, 1200 with 2 side brushes | |
| Area performance: | m ² | 4200 without side brush | 4200 without side brush |
| (max. theoretical | m ² | 5700 with 1 side brush | 5700 with 1 side brush |
| area performance): | m ² | 7200 with 2 side brushes | 7200 with 2 side brushes |
| Sweeping speed up to: | km/h | 6 | 6 |
| Climbing ability up to: | % | 16 | 16 |
| Running time up to: | h | 4,5 | 4,5 |
| Length with side brush: | mm | 1500 | 1500 |
| Width: | mm | 1000 | 1000 |
| Overall height: | mm | 1330 | 1330 |
| Weight, ready for operation: | kg | 350 | |
| with drive batteries: | kg | | 440 |

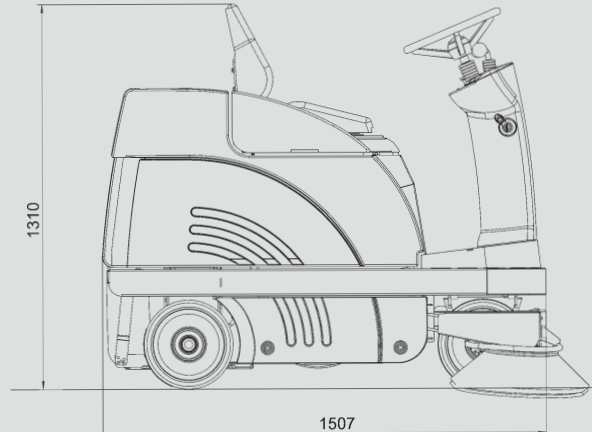
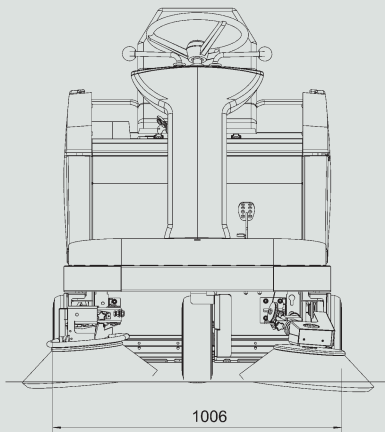

The Hako-Jonas 980 offers the highest product quality and long machine life as a result of modern manufacturing processes and a strict quality assurance system. The Hako-Jonas 980 has been manufactured in accordance with the necessary CE guidelines (CE conformity) and fulfils the European safety norms EN 60 204 and EN 60 335.

In the interest of technical progress we reserve the right to alter equipment without prior notice.

Hako is the right partner:

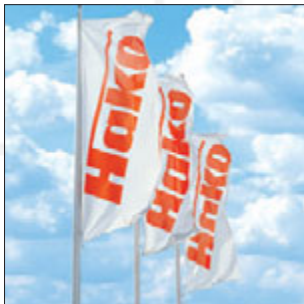

Cleanliness with safety
Hako machines adhere to strict quality regulations/standards. Quality made by Hako. We also take care of what we sell – World-wide.



Sales, hire, leasing, rental
Hako allows you to individually plan capital investments depending upon customer's demands and the available means.

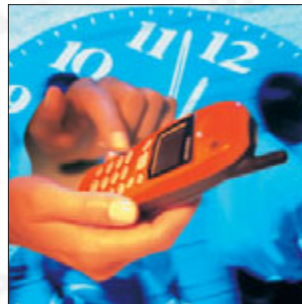

We are there for you day and night
Reliable after-sales service and excellent logistics guarantee that machines can be ready for operation around the clock.



Hako is never far away
The efficient Hako sales and service network means that Hako is always close at hand.



Superior technology for a cleaner, more pleasant environment.

Hako-Werke GmbH
Hamburger Straße 209-239
D-23843 Bad Oldesloe
Phone: ++49 45 31 8 06-0
Fax: ++49 45 31 8 06-3 38
Internet: www.hako.com
E-mail: info@hako.com



The Hako sales and service office is always close at hand.